



### The Final Evolution of the R32 Monobloc

The R32 Monobloc S II is the ultimate evolution of the R32 Monobloc series, with all the benefits of the R32 Monobloc S in a sleek gray European design.

### What is R32 Monobloc S II

The THERMA V R32 Monobloc S II is the next generation model that continues the legacy of the LG THERMA V R32 Monobloc S. The new generation's sleek look matches that of the rest of the modernized line-up, while maintaining the excellent performance of the existing R32 Monobloc S, and that the single fan design has been applied to not only the 5, 7, and 9 kW but also the 12, 14, and 16 kW models. Along with these design changes, various features and installation conveniences that were developed from the R290 Monobloc have been reflected.

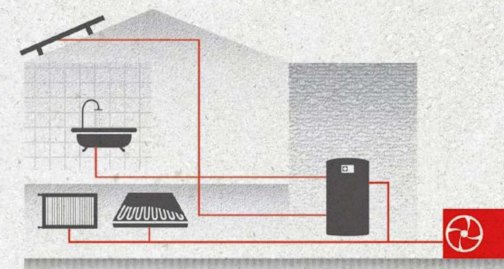

### Key Features

- Capacity range from 5 to 16 kW for new build and renovation
- Refined gray design that adapt to various surroundings
- Standalone heat pump allowing easy installation (Plug and play solution)
- ErP Energy Labeling A+++ / A++ for space heating (Average Climate 35°C / 55°C LWT)
- Low noise level for high installation flexibility
- 100% Heating capacity at -15°C outdoor temperature (16 kW 90%)
- Maximum flow temperature up to 65°C
- Operation range down to -25°C



### Product Range

Phase	Capacity (kW)	Outdoor Unit
1 Ø	5	HM051MRS UA40
	7	HM071MRS UA40
	9	HM091MRS UA40
	12	HM121MRS UB40
	14	HM141MRS UB40
	16	HM161MRS UB40
3 Ø	12	HM123MRS UB40
	14	HM143MRS UB40
	16	HM163MRS UB40

# HIGHLIGHT OF R32 MONOBLOC S II



[Browse now](#)

## New Design

### European-style Gray



### Enhanced Convenience



- Outdoor units design meets European standards
- Refined gray design that will look great anywhere
- 2 feet instead of 3 feet which was uncomfortable

## Improved Structure

### Prevent Cumulative Icing

Elimination of side panel and rear grille to prevent ice build-up

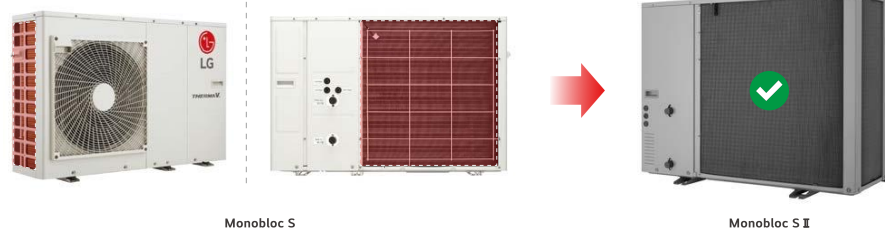

## Space Efficiency

### Simpler Exterior

- Integrated hydronic components in the package
- Easier and quicker installation without refrigerant piping work
- The best solution, when interior space is limited



## Comfortable Ease

### Low Noise Level Allowing Installation Flexibility

- Designed to reach lower noise levels in order to meet homeowner expectations in urban areas
- Noise reduction technology such as encapsulated compressor and vibration-decoupling to ensure a quieter and more comfortable experience



## Reliable Performance

### Remarkable Heating Performance even in Cold Weather

- 100 % heating capacity at -15 °C ambient temp. (@LWT 35 °C, except for 16 kW model)
- Longer continuous heating periods with reduced defrost operation time and extended intervals



## Convenience

### Easy Maintenance

Easy access to PCB for installing and maintenance

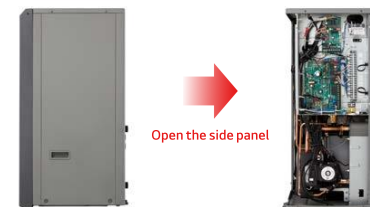

### Separate Supply of Strainer

Easy strainer cleaning by not opening the panel



# THERMA V R32 MONOBLOC S II (5/7/9 kW)

## Outdoor unit

HM051MRS UA40  
HM071MRS UA40  
HM091MRS UA40



## Key Components

### Outdoor Unit

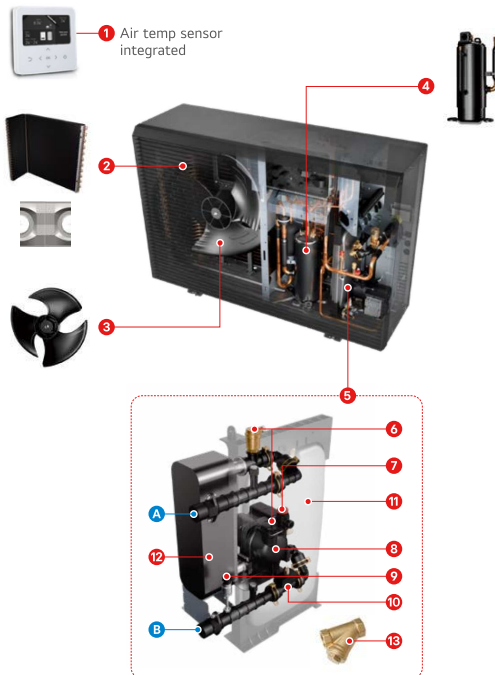

### Components

- 1 Standard III remote controller<sup>1)2)</sup>
- 2 Black Fin heat exchanger (air / ref.)
- 3 Biomimetic fan
- 4 R1 compressor
- 5 Hydronic components assembly
- 6 Air vent valve
- 7 Safety valve
- 8 Water pump
- 9 Pressure sensor
- 10 Flow sensor
- 11 Expansion tank (8l)
- 12 Plate heat exchanger
- 13 Strainer (loose supplied)

1) The remote controller is supplied with the product, but it needs to be installed separately.  
2) Temperature control class (ERP class): -V

### Connections

- A Leaving water pipe (male PT 1")
- B Entering water pipe (male PT 1")

## Product Specification

Efficiency Data	Unit	5 kW (1 Ø)	7 kW (1 Ø)	9 kW (1 Ø)	
Seasonal space heating eff. class (35°C / 55°C)	-	A+++ / A++	A+++ / A++	A+++ / A++	
Seasonal space heating efficiency ( $\eta_p$ ) (35°C / 55°C)	%	175 / 125	176 / 125	179 / 125	
SCOP (35°C / 55°C)	-	4.46 / 3.20	4.48 / 3.20	4.55 / 3.20	
Sound power level	Rated / low noise mode	dB(A)	57 / 54	57 / 55	
Sound pressure level at 5m	Rated / low noise mode	dB(A)	35 / 32	35 / 33	
Nominal Capacity and COP/EER					
Air +7°C / water +35°C	Heating capacity / COP	kW / -	5.50 / 4.70	7.00 / 4.70	
Air +2°C / water +35°C	Heating capacity / COP	kW / -	5.50 / 3.60	6.00 / 3.55	
Air +7°C / water +55°C	Heating capacity / COP	kW / -	5.50 / 2.70	6.00 / 2.70	
Air +35°C / water +18°C	Cooling capacity / EER	kW / -	5.50 / 4.70	7.00 / 4.65	
Air +35°C / water +7°C	Cooling capacity / EER	kW / -	5.50 / 3.30	7.00 / 3.20	
Outdoor Units		Unit	HM051MRS UA40	HM071MRS UA40	HM091MRS UA40
Operation range (outdoor air temperature)	Heating & DHW (Min. - Max.)	°C	-25 - 35		
	Cooling (Min. - Max.)	°C	5 - 48		
Operation range (leaving water temperature)	Heating (Min. - Max.)	°C	15 - 65		
	Cooling (Min. - Max.)	°C	5 - 27		
	DHW (Min. - Max.)	°C	15 - 80		
Refrigerant	Type	-	R32		
	GWP	-	675		
	Precharged amount	g	1,400		
Piping connections (water)	Inlet / outlet diameter	inch	Male PT 1" according to ISO 7-1 (tapered pipe threads)		
Expansion vessel (heating circuit)	Volume	l	8		
Dimension	H x W x D	mm	853 x 1,242 x 391		
Weight	Net	kg	94		
Exterior	Color of chassis / RAL code	-	Dawn gray / RAL 7037		
	Color of front grille / RAL code	-	Dark dawn gray / RAL 7012		
Power supply	Voltage, phase, frequency	V, Ø, Hz	220 - 240, 1, 50		
	Standby power consumption	W	10		
	Recommended circuit breaker	A	16	20	25

### Note

1. Due to our policy of innovation, some specifications may be changed without notification.
2. Wiring cable size must comply with the applicable local and national codes. Especially the power cable and circuit breaker should be selected in accordance with that.
3. Sound power level is measured on the rated condition in accordance with ISO 9614 standard. Sound pressure level is not a value declared on Eurovent Program and is converted from sound power level based on a tonality penalty of 0 dB and installation in free-field. The directivity index (Q) is assumed as 2. Therefore, these values can be increased owing to ambient conditions during operation. Rated sound power level is in accordance with EN12102-1 under condition of EN14825.
4. Performances are in accordance with EN14511 and reflect ErP testing conditions. Above gives the declared values at rated conditions according to ErP regulation.
5. This product contains fluorinated greenhouse gases.
6. All installation sites must be equipped with an earth leakage circuit breaker (ELCB).
7. DHW 55 - 80°C Operating is available only when the booster heater is operating.

# THERMA V R32 MONOBLOC S II (5/7/9 kW)

## Performance Table for Heating Operation

Maximum heating capacity (Include defrost effect)

### HM051MRS UA40

Outdoor Temp. [°C DB]	LWT 30 °C	LWT 35 °C	LWT 40 °C	LWT 45 °C	LWT 50 °C	LWT 55 °C	LWT 60 °C	LWT 65 °C
	Capacity (kW)							
-25	5.50	5.50	5.50	5.50	-	-	-	-
-20	5.50	5.50	5.50	5.50	5.23	-	-	-
-15	5.50	5.50	5.50	5.50	5.23	5.23	-	-
-7	5.50	5.50	5.50	5.50	5.50	5.50	5.50	-
-4	5.50	5.50	5.50	5.50	5.50	5.50	5.50	5.50
-2	5.50	5.50	5.50	5.50	5.50	5.50	5.50	5.50
2	5.50	5.50	5.50	5.50	5.50	5.50	5.50	5.50
7	5.50	5.50	5.50	5.50	5.50	5.50	5.50	5.50
10	5.50	5.50	5.50	5.50	5.50	5.50	5.50	5.50
15	5.50	5.50	5.50	5.50	5.50	5.50	5.50	5.50
18	5.50	5.50	5.50	5.50	5.50	5.50	5.50	5.50
20	5.50	5.50	5.50	5.50	5.50	5.50	5.50	5.50
35	5.50	5.50	5.50	5.50	5.50	5.50	5.50	5.50

### HM071MRS UA40

Outdoor Temp. [°C DB]	LWT 30 °C	LWT 35 °C	LWT 40 °C	LWT 45 °C	LWT 50 °C	LWT 55 °C	LWT 60 °C	LWT 65 °C
	Capacity (kW)							
-25	5.85	5.85	5.85	5.85	-	-	-	-
-20	6.43	6.43	6.43	6.43	6.10	-	-	-
-15	7.00	7.00	7.00	7.00	6.65	6.65	-	-
-7	7.00	7.00	7.00	7.00	7.00	7.00	7.00	-
-4	7.00	7.00	7.00	7.00	7.00	7.00	7.00	7.00
-2	7.00	7.00	7.00	7.00	7.00	7.00	7.00	7.00
2	7.00	7.00	7.00	7.00	7.00	7.00	7.00	7.00
7	7.00	7.00	7.00	7.00	7.00	7.00	7.00	7.00
10	7.00	7.00	7.00	7.00	7.00	7.00	7.00	7.00
15	7.00	7.00	7.00	7.00	7.00	7.00	7.00	7.00
18	7.00	7.00	7.00	7.00	7.00	7.00	7.00	7.00
20	7.00	7.00	7.00	7.00	7.00	7.00	7.00	7.00
35	7.00	7.00	7.00	7.00	7.00	7.00	7.00	7.00

### HM091MRS UA40

Outdoor Temp. [°C DB]	LWT 30 °C	LWT 35 °C	LWT 40 °C	LWT 45 °C	LWT 50 °C	LWT 55 °C	LWT 60 °C	LWT 65 °C
	Capacity (kW)							
-25	6.20	6.20	6.20	6.20	-	-	-	-
-20	7.60	7.60	7.60	7.60	7.22	-	-	-
-15	9.00	9.00	9.00	9.00	8.55	8.55	-	-
-7	9.00	9.00	9.00	9.00	9.00	9.00	9.00	-
-4	9.00	9.00	9.00	9.00	9.00	9.00	9.00	9.00
-2	9.00	9.00	9.00	9.00	9.00	9.00	9.00	9.00
2	9.00	9.00	9.00	9.00	9.00	9.00	9.00	9.00
7	9.00	9.00	9.00	9.00	9.00	9.00	9.00	9.00
10	9.00	9.00	9.00	9.00	9.00	9.00	9.00	9.00
15	9.00	9.00	9.00	9.00	9.00	9.00	9.00	9.00
18	9.00	9.00	9.00	9.00	9.00	9.00	9.00	9.00
20	9.00	9.00	9.00	9.00	9.00	9.00	9.00	9.00
35	9.00	9.00	9.00	9.00	9.00	9.00	9.00	9.00

Note

1. DB : Dry Bulb Temperature (°C), LWT : Leaving Water Temperature (°C), LPM : Liters Per Minute (l/min), TC : Total Capacity (kW)
2. Direct interpolation is permissible. Do not extrapolate.
3. Measuring procedure follows EN-14511.
  - Rated values are based on standard conditions and it can be found on specifications.
  - Above table values may not be matched according to installation condition. Except for rated value, the performance is not guaranteed.
  - In accordance with the test standard (or nations), the rating will vary slightly.
4. The shaded areas are not guaranteed continuous operation.

## Performance Table for Cooling Operation

Maximum cooling capacity

### HM051MRS UA40

Outdoor Temp. [°C DB]	LWT 7 °C	LWT 10 °C	LWT 13 °C	LWT 15 °C	LWT 18 °C	LWT 20 °C	LWT 22 °C
	Capacity (kW)						
10	5.50	5.50	5.50	5.50	5.50	5.50	5.50
20	5.50	5.50	5.50	5.50	5.50	5.50	5.50
30	5.50	5.50	5.50	5.50	5.50	5.50	5.50
35	5.50	5.50	5.50	5.50	5.50	5.50	5.50
40	5.29	5.32	5.36	5.38	5.41	5.43	5.45
45	5.09	5.15	5.21	5.25	5.31	5.36	5.40

### HM071MRS UA40

Outdoor Temp. [°C DB]	LWT 7 °C	LWT 10 °C	LWT 13 °C	LWT 15 °C	LWT 18 °C	LWT 20 °C	LWT 22 °C
	Capacity (kW)						
10	7.00	7.00	7.00	7.00	7.00	7.00	7.00
20	7.00	7.00	7.00	7.00	7.00	7.00	7.00
30	7.00	7.00	7.00	7.00	7.00	7.00	7.00
35	7.00	7.00	7.00	7.00	7.00	7.00	7.00
40	6.36	6.45	6.55	6.61	6.71	6.77	6.84
45	5.71	5.82	5.92	5.99	6.10	6.17	6.24

### HM091MRS UA40

Outdoor Temp. [°C DB]	LWT 7 °C	LWT 10 °C	LWT 13 °C	LWT 15 °C	LWT 18 °C	LWT 20 °C	LWT 22 °C
	Capacity (kW)						
10	9.00	9.00	9.00	9.00	9.00	9.00	9.00
20	9.00	9.00	9.00	9.00	9.00	9.00	9.00
30	9.00	9.00	9.00	9.00	9.00	9.00	9.00
35	9.00	9.00	9.00	9.00	9.00	9.00	9.00
40	7.66	7.66	7.65	7.65	7.65	7.65	7.65
45	6.31	6.35	6.39	6.42	6.45	6.48	6.51

Note

1. DB : Dry Bulb Temperature (°C), LWT : Leaving Water Temperature (°C), LPM : Liters Per Minute (l/min), TC : Total Capacity (kW)
2. Direct interpolation is permissible. Do not extrapolate.
3. Measuring procedure follows EN-14511.
  - Rated values are based on standard conditions and it can be found on specifications.
  - Above table values may not be matched according to installation condition. Except for rated value, the performance is not guaranteed.
  - In accordance with the test standard (or nations), the rating will vary slightly.
4. The shaded areas are not guaranteed continuous operation.

## Supplied Parts

### Strainer



Technical Specification		Unit	Details
Material	Body	-	Brass
	Mesh	-	Stainless steel (STS304)
Mesh	Mesh no.	-	30
	Max. particle size	mm	0.6
Piping connection		-	Female G1" according to ISO 228-1

- \* The strainer and valves are supplied with the product, but it need to be installed separately.
- \* This strainer should be installed at the inlet connection of the outdoor unit to protect the clogging of a plate heat exchanger.

# THERMA V R32 MONOBLOC S II (5/7/9 kW)

## Drawings

[Unit: mm]

[Unit: mm]

HMO51MRS UA40  
HMO71MRS UA40  
HMO91MRS UA40

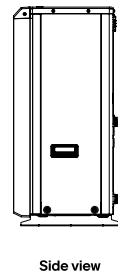
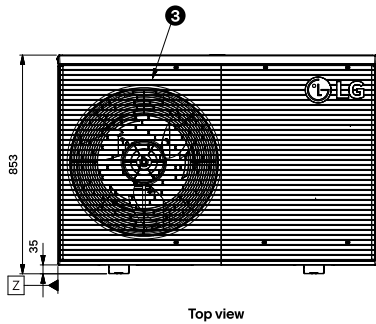
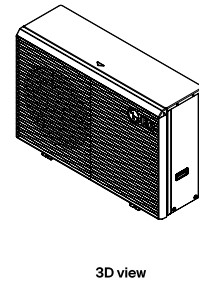
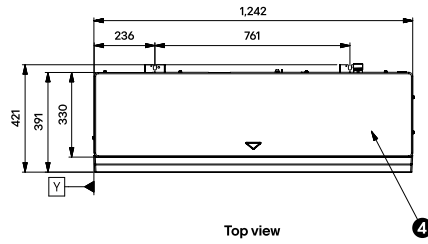

Drain holes for drain cap (7EA)  
Note:  
If you need more drains, remove them

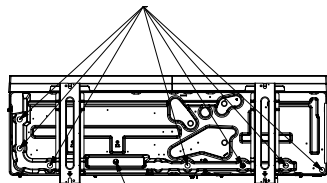

4-holes for anchor bolts (M10)  
Drain hole for drain nipple (1EA)  
Bottom view

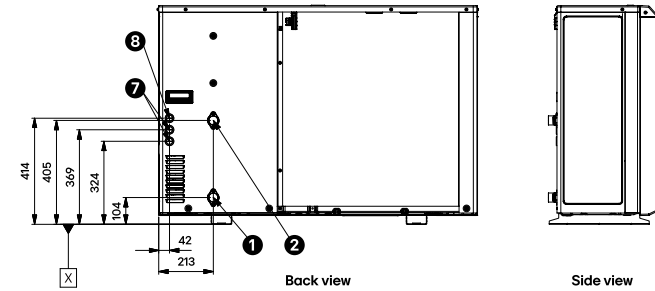
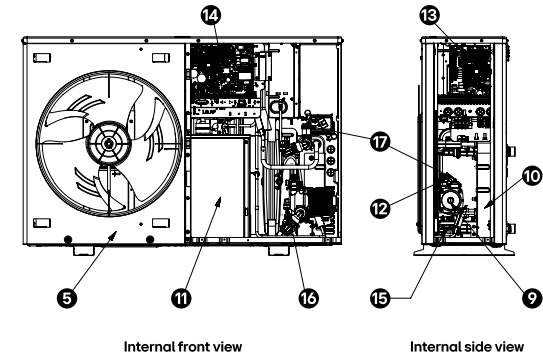

No.	Part Name	Description
1	Entering Water Pipe	Male PT 1" according to ISO 7-1 (Tapered pipe threads)
2	Leaving Water Pipe	Male PT 1" according to ISO 7-1 (Tapered pipe threads)
3	Air Discharge Grille	-
4	Top Cover	-
5	Front Panel	-
6	Side Panel	-
7	Low Voltage	Communication Cable Hole
8	UNIT Power	Power Cable Hole
9	Water Pump	OH SUNG, ODM-061P / GRUNDFOS, UPM3K 20-75 CHBL
10	Plate Heat Exchanger	Heat Exchanger Between Refrigerant and Water
11	Compressor Shield Panel	-
12	Safety Relief Valve	Open at Water Pressure 3 Bar
13	Indoor Control Box	Hydro, Cycle PCB and Terminal Blocks
14	Outdoor Control Box	Inverter PCB and Terminal Blocks
15	Flow Sensor	SIKA VVX20 / SEBA LGF-080-C20-E-0.5V, 5-80 LPM
16	Water Pressure Sensor	SENSATA 2HMP3-05W 02-MPa
17	Automatic Air Vents	-

# THERMA V R32 MONOBLOC S II (12 / 14 / 16 kW)

## Outdoor unit

HM121MRS UB40 / HM123MRS UB40  
HM141MRS UB40 / HM143MRS UB40  
HM161MRS UB40 / HM163MRS UB40



## Key Components

### Outdoor Unit

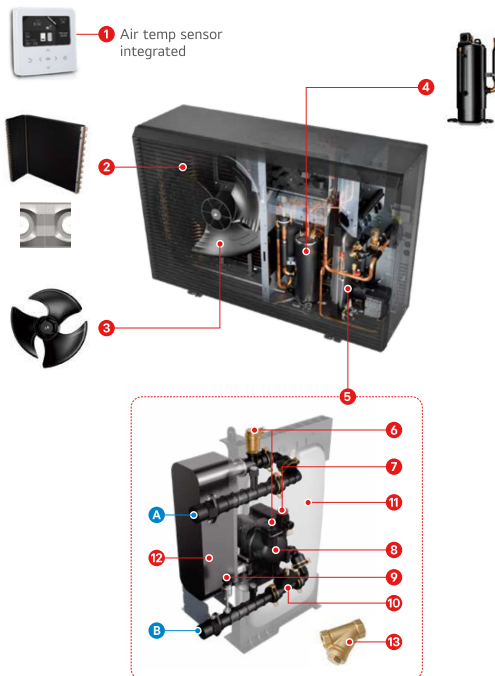

### Components

- 1 Standard III remote controller<sup>1) 2)</sup>
- 2 Black Fin heat exchanger (air / ref.)
- 3 Biomimetic fan
- 4 R1 compressor
- 5 Hydronic components assembly
- 6 Air vent valve
- 7 Safety valve
- 8 Water pump
- 9 Pressure sensor
- 10 Flow sensor
- 11 Expansion tank (8l)
- 12 Plate heat exchanger
- 13 Strainer (loose supplied)

- 1) The remote controller is supplied with the product, but it needs to be installed separately.
- 2) Temperature control class (ERP class): V

### Connections

- A Leaving water pipe (male PT 1")
- B Entering water pipe (male PT 1")

## Product Specification

Efficiency Data		Unit	12 kW (1 Ø) 12 kW (3 Ø)	14 kW (1 Ø) 14 kW (3 Ø)	16 kW (1 Ø) 16 kW (3 Ø)
Seasonal space heating eff. class (35°C / 55°C)		-	A+++ / A++	A+++ / A++	A+++ / A++
Seasonal space heating efficiency ( $\eta_s$ ) (35°C / 55°C)		%	184 / 136	182 / 135	178 / 135
SCOP (35°C / 55°C)		-	4.67 / 3.47	4.62 / 3.46	4.53 / 3.45
Sound power level	Rated / low noise mode	dB(A)	60 / 56	61 / 57	61 / 57
Sound pressure level at 5m	Rated / low noise mode	dB(A)	38 / 34	39 / 35	39 / 35
Nominal Capacity and COP/EER					
Air +7°C / water +35°C	Heating capacity / COP	kW / -	12.00 / 4.90	14.00 / 4.80	16.00 / 4.70
Air +2°C / water +35°C	Heating capacity / COP	kW / -	11.00 / 3.60	12.00 / 3.55	13.80 / 3.50
Air +7°C / water +55°C	Heating capacity / COP	kW / -	11.00 / 2.90	11.50 / 2.85	12.00 / 2.80
Air +35°C / water +18°C	Cooling capacity / EER	kW / -	12.00 / 4.80	14.00 / 4.70	16.00 / 4.60
Air +35°C / water +7°C	Cooling capacity / EER	kW / -	12.00 / 3.20	14.00 / 3.10	15.00 / 3.00
Outdoor Units		Unit	HM121MRS UB40 HM123MRS UB40	HM141MRS UB40 HM143MRS UB40	HM161MRS UB40 HM163MRS UB40
Operation range (outdoor air temperature)	Heating & DHW (Min. - Max.)	°C	-25 - 35		
	Cooling (Min. - Max.)	°C	5 - 48		
Operation range (leaving water temperature)	Heating (Min. - Max.)	°C	15 - 65		
	Cooling (Min. - Max.)	°C	5 - 27		
	DHW (Min. - Max.)	°C	15 - 80		
Refrigerant	Type	-	R32		
	GWP	-	675		
	Precharged amount	g	1,600		
Piping connections (water)	Inlet / outlet diameter	inch	Male PT 1" according to ISO 7-1 (tapered pipe threads)		
Expansion vessel (heating circuit)	Volume	l	8		
Dimension	H x W x D	mm	1,019 x 1,320 x 520		
Weight	Net	kg	117		
Exterior	Color of chassis / RAL code	-	Dawn gray / RAL 7037		
	Color of front grille / RAL code	-	Dark dawn gray / RAL 7012		
Power supply	Voltage, phase, frequency	V, Ø, Hz	220 - 240, 1, 50 / 380 - 415, 3, 50		
	Standby power consumption	W	10		
	Recommended circuit breaker	A	40 / 16		

### Note

1. Due to our policy of innovation, some specifications may be changed without notification.
2. Wiring cable size must comply with the applicable local and national codes. Especially the power cable and circuit breaker should be selected in accordance with that.
3. Sound power level is measured on the rated condition in accordance with ISO 9614 standard. Sound pressure level is not a value declared on Eurovent Program and is converted from sound power level based on a tonality penalty of 0 dB and installation in free-field. The directivity index (Q) is assumed as 2. Therefore, these values can be increased owing to ambient conditions during operation. Rated sound power level is in accordance with EN12102-1 under condition of EN14825.
4. Performances are in accordance with EN14511 and reflect ErP testing conditions. Above gives the declared values at rated conditions according to ErP regulation.
5. This product contains fluorinated greenhouse gases.
6. All installation sites must be equipped with an earth leakage circuit breaker (ELCB).
7. DHW 55 - 80°C Operating is available only when the booster heater is operating.

# THERMA V R32 MONOBLOC S II (12 / 14 / 16 kW)

## Performance Table for Heating Operation

Maximum heating capacity (Include defrost effect)

### HM121MRS UB40 / HM123MRS UB40

Outdoor Temp. [°C DB]	LWT 30 °C	LWT 35 °C	LWT 40 °C	LWT 45 °C	LWT 50 °C	LWT 55 °C	LWT 60 °C	LWT 65 °C
	Capacity (kW)							
-25	9.50	9.50	9.50	9.50	-	-	-	-
-20	10.75	10.75	10.75	10.75	10.21	-	-	-
-15	12.00	12.00	12.00	12.00	11.50	11.50	-	-
-7	12.00	12.00	12.00	12.00	12.00	12.00	12.00	-
-4	12.00	12.00	12.00	12.00	12.00	12.00	12.00	12.00
-2	12.00	12.00	12.00	12.00	12.00	12.00	12.00	12.00
2	12.00	12.00	12.00	12.00	12.00	12.00	12.00	12.00
7	12.00	12.00	12.00	12.00	12.00	12.00	12.00	12.00
10	12.00	12.00	12.00	12.00	12.00	12.00	12.00	12.00
15	12.00	12.00	12.00	12.00	12.00	12.00	12.00	12.00
18	12.00	12.00	12.00	12.00	12.00	12.00	12.00	12.00
20	12.00	12.00	12.00	12.00	12.00	12.00	12.00	12.00
35	12.00	12.00	12.00	12.00	12.00	12.00	12.00	12.00

### HM141MRS UB40 / HM143MRS UB40

Outdoor Temp. [°C DB]	LWT 30 °C	LWT 35 °C	LWT 40 °C	LWT 45 °C	LWT 50 °C	LWT 55 °C	LWT 60 °C	LWT 65 °C
	Capacity (kW)							
-25	10.00	10.00	10.00	10.00	-	-	-	-
-20	12.00	12.00	12.00	12.00	11.40	-	-	-
-15	14.00	14.00	14.00	14.00	13.30	13.30	-	-
-7	14.00	14.00	14.00	14.00	14.00	14.00	14.00	-
-4	14.00	14.00	14.00	14.00	14.00	14.00	14.00	14.00
-2	14.00	14.00	14.00	14.00	14.00	14.00	14.00	14.00
2	14.00	14.00	14.00	14.00	14.00	14.00	14.00	14.00
7	14.00	14.00	14.00	14.00	14.00	14.00	14.00	14.00
10	14.00	14.00	14.00	14.00	14.00	14.00	14.00	14.00
15	14.00	14.00	14.00	14.00	14.00	14.00	14.00	14.00
18	14.00	14.00	14.00	14.00	14.00	14.00	14.00	14.00
20	14.00	14.00	14.00	14.00	14.00	14.00	14.00	14.00
35	14.00	14.00	14.00	14.00	14.00	14.00	14.00	12.50

### HM161MRS UB40 / HM163MRS UB40

Outdoor Temp. [°C DB]	LWT 30 °C	LWT 35 °C	LWT 40 °C	LWT 45 °C	LWT 50 °C	LWT 55 °C	LWT 60 °C	LWT 65 °C
	Capacity (kW)							
-25	10.50	10.50	10.50	10.50	-	-	-	-
-20	13.25	13.25	13.25	13.25	12.59	-	-	-
-15	16.00	14.40	14.40	14.40	13.68	13.68	-	-
-7	16.00	16.00	16.00	16.00	16.00	16.00	16.00	-
-4	16.00	16.00	16.00	16.00	16.00	16.00	16.00	16.00
-2	16.00	16.00	16.00	16.00	16.00	16.00	16.00	16.00
2	16.00	16.00	16.00	16.00	16.00	16.00	16.00	16.00
7	16.00	16.00	16.00	16.00	16.00	16.00	16.00	16.00
10	16.00	16.00	16.00	16.00	16.00	16.00	16.00	16.00
15	16.00	16.00	16.00	16.00	16.00	16.00	16.00	16.00
18	16.00	16.00	16.00	16.00	16.00	16.00	16.00	16.00
20	16.00	16.00	16.00	16.00	16.00	16.00	16.00	16.00
35	16.00	16.00	16.00	16.00	16.00	16.00	16.00	13.00

Note

1. DB : Dry Bulb Temperature (°C), LWT : Leaving Water Temperature (°C), LPM : Liters Per Minute (ℓ/min), TC : Total Capacity (kW)
2. Direct interpolation is permissible. Do not extrapolate.
3. Measuring procedure follows EN-14511.
  - Rated values are based on standard conditions and it can be found on specifications.
  - Above table values may not be matched according to installation condition. Except for rated value, the performance is not guaranteed.
  - In accordance with the test standard (or nations), the rating will vary slightly.
4. The shaded areas are not guaranteed continuous operation.

## Performance Table for Cooling Operation

Maximum cooling capacity

### HM121MRS UB40 / HM123MRS UB40

Outdoor Temp. [°C DB]	LWT 7 °C	LWT 10 °C	LWT 13 °C	LWT 15 °C	LWT 18 °C	LWT 20 °C	LWT 22 °C
	Capacity (kW)						
10	12.00	12.00	12.00	12.00	12.00	12.00	12.00
20	12.00	12.00	12.00	12.00	12.00	12.00	12.00
30	12.00	12.00	12.00	12.00	12.00	12.00	12.00
35	12.00	12.00	12.00	12.00	12.00	12.00	12.00
40	11.05	11.19	11.33	11.43	11.57	11.67	11.76
45	10.10	10.37	10.64	10.83	11.10	11.28	11.46

### HM141MRS UB40 / HM143MRS UB40

Outdoor Temp. [°C DB]	LWT 7 °C	LWT 10 °C	LWT 13 °C	LWT 15 °C	LWT 18 °C	LWT 20 °C	LWT 22 °C
	Capacity (kW)						
10	12.50	12.80	13.10	13.30	13.60	13.80	14.00
20	14.00	14.00	14.00	14.00	14.00	14.00	14.00
30	14.00	14.00	14.00	14.00	14.00	14.00	14.00
35	14.00	14.00	14.00	14.00	14.00	14.00	14.00
40	12.35	12.60	12.84	13.01	13.26	13.42	13.59
45	10.69	11.19	11.69	12.02	12.51	12.84	13.17

### HM161MRS UB40 / HM163MRS UB40

Outdoor Temp. [°C DB]	LWT 7 °C	LWT 10 °C	LWT 13 °C	LWT 15 °C	LWT 18 °C	LWT 20 °C	LWT 22 °C
	Capacity (kW)						
10	13.00	13.60	14.20	14.60	15.20	15.60	16.00
20	16.00	16.00	16.00	16.00	16.00	16.00	16.00
30	16.00	16.00	16.00	16.00	16.00	16.00	16.00
35	16.00	16.00	16.00	16.00	16.00	16.00	16.00
40	13.60	13.96	14.32	14.56	14.92	15.16	15.40
45	11.20	11.76	12.32	12.69	13.25	13.62	14.00

Note

1. DB : Dry Bulb Temperature (°C), LWT : Leaving Water Temperature (°C), LPM : Liters Per Minute (ℓ/min), TC : Total Capacity (kW)
2. Direct interpolation is permissible. Do not extrapolate.
3. Measuring procedure follows EN-14511.
  - Rated values are based on standard conditions and it can be found on specifications.
  - Above table values may not be matched according to installation condition. Except for rated value, the performance is not guaranteed.
  - In accordance with the test standard (or nations), the rating will vary slightly.
4. The shaded areas are not guaranteed continuous operation.

## Supplied Parts

### Strainer



Technical Specification		Unit	Details
Material	Body	-	Brass
	Mesh	-	Stainless steel (STS304)
Mesh	Mesh no.	-	30
	Max. particle size	mm	0.6
Piping connection		-	Female G1" according to ISO 228-1

- \* The strainer and valves are supplied with the product, but it need to be installed separately.
- \* This strainer should be installed at the inlet connection of the outdoor unit to protect the clogging of a plate heat exchanger.

# THERMA V R32 MONOBLOC S II (12/14/16 kW)

## Drawings

[Unit: mm]

HM121MRS UB40 / HM123MRS UB40  
HM141MRS UB40 / HM143MRS UB40  
HM161MRS UB40 / HM163MRS UB40

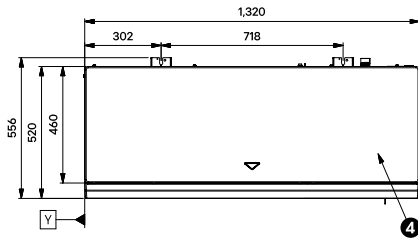

Top view

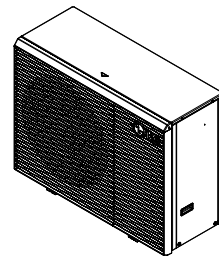

3D view

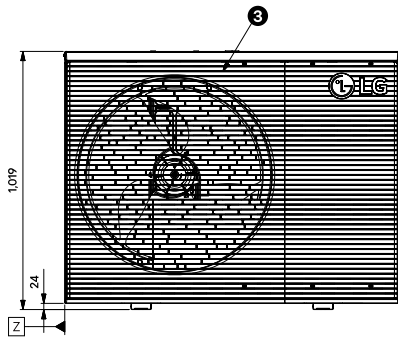

Top view

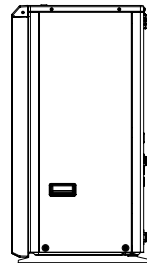

Side view

Drain holes for drain cap (7EA)  
Note:  
If you need more drains, remove them

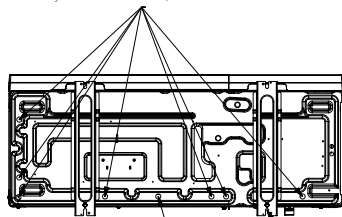

Bottom view

[Unit: mm]

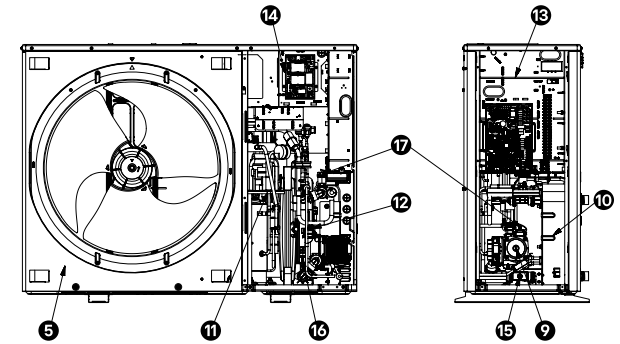

Internal front view

Internal side view

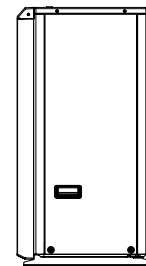

Side view

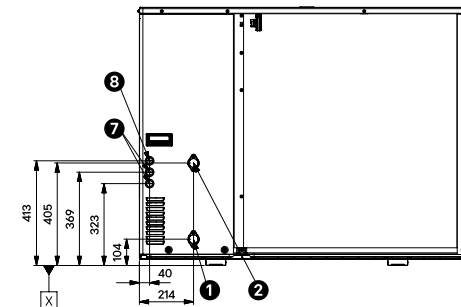

Back view

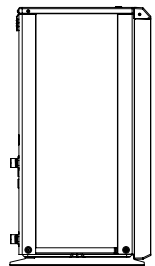

Side view

No.	Part Name	Description
1	Entering Water Pipe	Male PT 1" according to ISO 7-1 (Tapered pipe threads)
2	Leaving Water Pipe	Male PT 1" according to ISO 7-1 (Tapered pipe threads)
3	Air Discharge Grille	-
4	Top Cover	-
5	Front Panel	-
6	Side Panel	-
7	Low Voltage	Communication Cable Hole
8	UNIT Power	Power Cable Hole
9	Water Pump	OH SUNG, ODM-061P / GRUNDFOS, UPM3K 20-75 CHBL
10	Plate Heat Exchanger	Heat Exchanger Between Refrigerant and Water
11	Compressor Shield Panel	-
12	Safety Relief Valve	Open at Water Pressure 3 Bar
13	Indoor Control Box	Hydro, Cycle PCB and Terminal Blocks
14	Outdoor Control Box	Inverter PCB and Terminal Blocks
15	Flow Sensor	SIKA VVX20 / SEBA LGF-080-C20-E-0.5V, 5-80 LPM
16	Water Pressure Sensor	SENSATA 2HMP3-05W 02-MPa
17	Automatic Air Vents	-