

VACdynamic 1.8



CARACTERÍSTICAS TÉCNICAS

Potencia (W)	1800
Caudal (m³/h)	210
Depresión (mm/H ₂ O)	3300
Airwatts	643
Superficie del filtro HEPA (cm²)	6000
Superficie del filtro Pro-Tecta (cm²)	1300
Cuba (L)	28
Nivel sonoro (dB)	≤60
Peso (kg)	16

Motor By-Pass perdiférico alta velocidad

RECOMENDACIONES DE INSTALACION

M² por vivienda	≤500
Distancia max. a la toma mas lejana (m)	50
Nº máximo de tomas	12

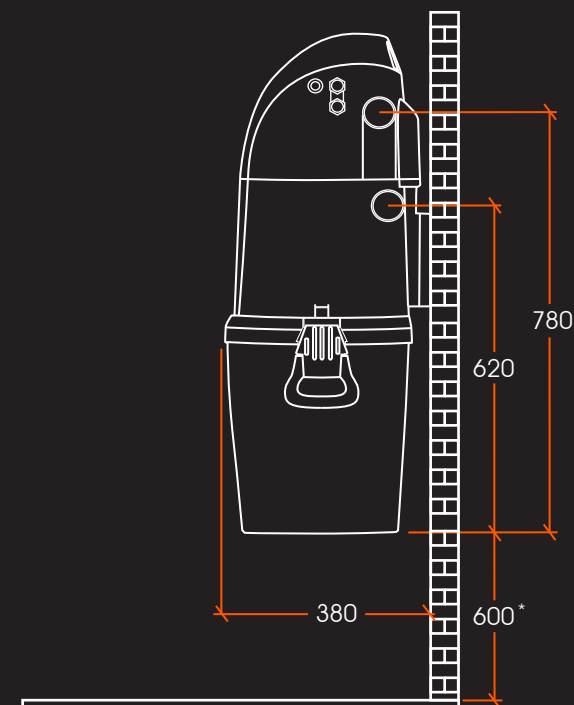
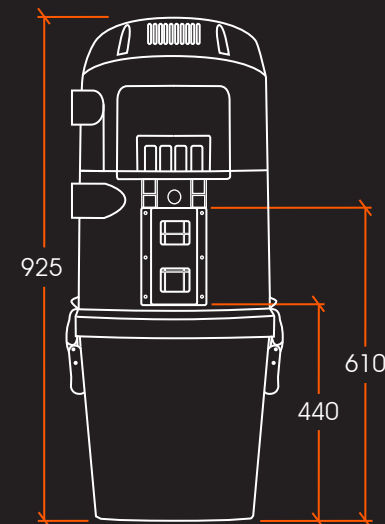

* Distancia mínima recomendada para un cómodo vaciado de la cuba